



## ECO60 HEATER

### User manual and installation instructions



Dear user, it is mandatory to observe and implement the provisions of this manual.

Please read and follow it carefully.

Otherwise, KOOLAK GOSTAR YAZD Company will not be responsible for potential accidents.

\*We appreciate your purchase\*

We are confident that you will be satisfied with your acquisition from KGY.



## ECO60

With the confirmation certificate of the European Union and four international standards, we affirm that the design and modeling of this equipment have been completed in our company. It possesses the quality and safety features authorized by the European Union.

	<p><b>To ensure the proper, effective and permanent performance of the heater, as well as your safety, we sincerely ask you to read this installation pamphlet carefully and completely. Pay attention to warnings and safety instructions before installation and for the repair and maintenance of the Heater.</b></p> <p><b>The consequences of not reading the latest version of the manual are the responsibility of the customer.</b></p> <p><b>You can always download the latest version of the user manual at <a href="http://www.kgy.ir">www.kgy.ir</a></b></p>
--	---

Table of Contents

**1 Introduction..... 5**

**1-1 Target groups..... 5**

        1-1-1 Target group requirements: ..... 5

**2 General information ..... 6**

    2-1 Signs ..... 6

    2-2 Special Safety Instructions ..... 6

    2-3 General Safety Regulations ..... 6

    2-4 Electrical Equipment ..... 7

    2-5 Maintenance ..... 7

    2-6 Spare Parts Ordering..... 8

    2-7 Responsibility ..... 8

    2-8 Warranty..... 8

    2-9 Power outage ..... 8

    2-10 First Aid ..... 9

    2-11 Wastage..... 9

    2-12 Call Information..... 9

**3 Technical Features ..... 10**

    3-1 ECO60 Heater introduction ..... 10

    3-2 Technical Features Chart..... 10

    3-3 Structure ..... 11

    3-4 Heater Dimensions ..... 11

        ..... 11

    3-5 System ..... 13

**4 Installation ..... 14**

    4-1 Installation obligations ..... 14

    4-2 Installation guide..... 14

    4-3 Connections..... 15

    4-4 Gasoil connection ..... 15

    4-5 Gas Pipeline ..... 16

    4-6 Flue Connection..... 17

    4-7 Channel Connection..... 18



---

<b>5</b>	<b>Initiation.....</b>	<b>19</b>
5-1	Electricity.....	19
5-2	Running.....	20
5-3	Adjustment .....	20
5-4	Repair and Maintenance .....	21
5-5	Service .....	21
<b>6</b>	<b>Spare Part .....</b>	<b>22</b>
<b>7</b>	<b>Ambient Thermostat.....</b>	<b>22</b>
7-1	Flue Pipe and H Cap.....	22
7-2	Air Transfer Duct .....	23
7-3	Burner .....	23

## 1 Introduction

This instruction has been compiled to guide you, dear consumer, not only in learning how to turn on the ECO60 Heater but also in understanding the general details of its electrical panel and gaining the ability to troubleshoot your system. Always keep a copy of this manual next to the Heater so that the operator can comprehend the safety tips, especially if they are not familiar with the ECO60 Heater. Share the following tips with anyone working with the Heater to prevent problems and potential injuries:

How to turn on and adjust the Heater:

Familiarize yourself with the process of turning on and adjusting the Heater for optimal performance.

How to turn on and off the Heater and operate the thermostat:

Learn the steps for powering up and shutting down the Heater, as well as effectively using the thermostat for temperature control.

How to control the heating system, flue, and channel installation:

Gain proficiency in managing the heating system and understand the installation process for the flue and channels.

Ensure the Heater is serviced by a technician once a year to guarantee its correct performance. Consult an expert to address any issues with the electric motor or burner.

By following these guidelines, you not only ensure the efficient operation of your ECO60 Heater but also prioritize safety.

### 1-1 Target groups

**These instructions are intended for:**

- Installers tasked with the assembly (if applicable) and/or mechanical installation of this heater.
- Electricians tasked with the electrical installation of this heater.
- Operators tasked with the operation of this heater.
- Maintenance technicians tasked with maintenance and troubleshooting of this heater.



#### 1-1-1 Target group requirements:

- Installers must have sufficient relevant experience or training in the installation of this type of Heaters.
- Electricians must be qualified electricians.
- Operators must have sufficient relevant experience or training in operating this type of Heaters.
- Maintenance technicians must have sufficient relevant experience or training in maintaining and troubleshooting this type of Heaters.



## 2 General information

### 2-1 Signs

While reading this manual you'll face these signs:

	<p><b>General Hazard Warning</b></p>
	<p><b>Electrical Hazard Warning</b></p>
	<p><b>Protective Glove Use</b></p>

### 2-2 Special Safety Instructions

	<p><b>Caution</b></p>	<p><b>This sign indicates a possible hazard or unsafe practice that could injure you or damage the heater.</b></p>
	<p><b>Attention</b></p>	<p><b>Next to this sign, you will find information on how to use the heater properly and efficiently and how to create an ideal environmental condition.</b></p>

### 2-3 General Safety Regulations

This Heater is designed for use in industrial halls, animal breeding halls, and greenhouses. Its use in other locations is only acceptable if approved by the company's consultants and technical experts. The producer is not liable for the consequences resulting from improper use, and the user bears full responsibility for potential incidents and damages.

- The presence of a factory-authorized serviceman is mandatory for the initiation, maintenance, and installation of the heater.
- Compliance with obligatory regulations for incident prevention, along with adherence to all other formal regulations such as occupational medicine and safety, is required.

**Caution:**

**This manual does not address the general hazards of fire. Call your local fire department for guidance and information.**

## 2-4 Electrical Equipment

	<p><b>In livestock and poultry farms, the accumulation of compost can lead to the formation of hazardous and poisonous gases, such as hydrogen sulfide (sewer gas) and methane. The presence of these gases can pose a serious risk, especially during activities like moving and washing the compost, potentially causing a significant explosion in the presence of fire.</b></p> <p><b>To prevent dangerous incidents, it is crucial to turn off the heating Heaters before moving and washing the compost. Additionally, adhere to the following safety measures:</b></p> <ul style="list-style-type: none"> <li>- <b>Close the doors during compost accumulation outdoors.</b></li> <li>- <b>Ensure constant air conditioning and ventilation</b></li> </ul>
---	---

- All the matters related to the maintenance and repair of the Heater must be handled by experts.
- Before initiating maintenance and repair procedures ensure the Heater is unplugged.
- Prior to starting the Heater, inspect all electrical wiring and make sure they are undamaged.
- Before activating the Heater, have electricians identify and replace any damaged wires and components within the system.
- Covering the electro-motors may elevate the temperature and potentially leading to damage the Heater and, in extreme cases, causing a fire.

## 2-5 Maintenance

	<p><b>Before performing maintenance and repairs ensure that the Heater is unplugged.</b></p>
---	--

### Caution:

For maintenance procedures on the Heater, refer to the manual. Any repairs must be carried out exclusively by the authorized servicemen of the company, and they should be entrusted with the task.

Maintenance, repairs, and cleanliness of the Heater should be conducted when the Heater is turned off, and the electro-motor has been stopped. This aspect should be taken into consideration even when addressing partial deficiencies during repairs

	<p><b>If there is a possibility of hand injury, use the protective gloves.</b></p>
---	--

After the repair process, the customer should be satisfied with the results. Do not restart equipment before implementing all safety considerations.

The exact technical features of spare parts must be provided, ensuring they possess the necessary quality features. This requirement ensures the originality of the parts.

### **2-6 Spare Parts Ordering**

when ordering the spare parts, consider the following points:

- Intended piece code with its description
- Bill's code of initial purchase
- Electrical features, such as 380Volt,3phase, 50 hertz

### **2-7 Responsibility**

Any change applied to the Heater without the supervision of company representatives absolve our responsibility for potential damages.

The consequences of unstandardized adjustment of the flame formation system rest on the customer; hence, it is recommended that all matters related to installation, initiation, service, repair and adjustment of the injection system and flame formation should be handled by factory-authorized servicemen or individual trained and confirmed by KOOLAK GOSTAR YAZD.

### **2-8 Warranty**

Always keep the warranty card with you to avail yourself of the warranty and after-sales service for KOOLAK GOSTAR YAZD products. The product specification plate, located on the Heater, must not be removed under any circumstances. This plate contains crucial electrical, mechanical, and identification information.

Each Heater is assigned a unique serial number, which is indicated on its respective plate. Retain the serial number for future reference.

### **2-9 Power outage**

It is recommended to install warning systems on your equipment to protect your assets, animals and plants.

In the event of power outage, an emergency power system with a voltage stabilizer regulator must be immediately activated. Contact your insurance company for more information.



## 2-10 First Aid

First Aid box should always be available in the workplace for immediate aid provision in case of incidents. Replace any material and instrument used as soon as possible. When seeking help, provide the following information:

- Where did the incident happen?
- What happened?
- How many people are injured?
- What kind of injuries happened?
- Who is reporting the incident?

## 2-11 Wastage

After installation or repair, dispose of packing and other waste materials in appropriate places (like retrieval)

## 2-12 Call Information

Factory Address: Iman Street – Hossein Abad Rismani – Yazd – Iran

Telephone number: 035-38369990-9 / 035-38369560-1

Website: [www.kgy.ir](http://www.kgy.ir)

Fax: 035-38369505

Email: [info@kgy.ir](mailto:info@kgy.ir)



**The contents of this manual may change without prior notice.  
If you encounter any errors or incorrect information, we would appreciate being informed.  
All photos, logos, and content in this booklet belong to KGY Company and copying them without mentioning the company's name is illegal.**

### 3 Technical Features

#### 3-1 ECO60 Heater introduction

ECO series Heaters, utilizing the latest technology globally, have secured a distinct position in the country's heating industry. These Heaters feature a multi-layer pressed boiler and exchanger, ensuring that the expelled air remains free from toxic pollutants resulting from the combustion process. The combination of reasonable pricing and high efficiency has captured the attention of consumers.

ECO60 Heaters, with a capacity of 60,000 kilocalories employ an axial fan with a specially designed capability to withstand 1400 revolutions per minute. This design generates an air flow with an impressive rate of 5600 cubic meters per hour, enabling rapid heating of the environment.

Another notable aspect of this product is the positioning of the burner in the lower part of the Heater and the fan in the upper section. This configuration transforms the heat exchanger inside the furnace into a non-uniform air flow exchanger, achieving an efficiency higher than 92%. The height of the device facilitates the suction of hot air gathered at the height, leading to a significant reduction in fuel consumption and the swift creation of warm and uniform air within the hall.

A distinctive feature of the ECO60 series Heaters is their minimal space requirement, occupying less than one square meter. This characteristic makes them ideal for sport halls and production spaces, minimizing the spatial footprint in these environments.

#### 3-2 Technical Features Chart

Technical specifications	ECO60
Power Supply (Ph-V-Hz)	1-220-50
Weight (Kg)	61
Power (W)	50
Gasoil Consumption (L/h)	4-1
Gas Consumption (m <sup>3</sup> /h)	5-1
Dimensions (cm) (diameter×height)	145×60
Heat Transfer Surface Area (m <sup>2</sup> )	3/3
Flue Diameter (cm)	15
Burner (Kcal/h)	80000-60000
Electric Motor (W-RPM)	270-1320
Fan Diameter (cm)	50
Air Outlet Dimensions (cm) (length×width)	57×31
Burner Inlet Pipe (cm) (Diameter×length)	9×10

**Table No.1 Technical Specifications**

### 3-3 Structure

The **ECO60** Heater features a robust body housing a 270W motor. Within the furnace structure, a combustion chamber and a heat exchanger are strategically placed. The incorporation of an axial fan designed to boost the air intake flow generates a high-speed flow of hot air- a crucial factor for halls with substantial dimensions.

The upward suction of the incoming strategically reintroduces the hot air trapped at the height of the hall into the overall hot air flow. The design effectively reduces the energy loss, resulting in a significant reduction in fuel consumption.

The Heater is designed for easy access to all burner equipment and electrical panels. Utilizing a Burner Control Unit (BCU), this Heater facilitates seamless operation, making it user friendly.

The **ECO60** Heater is capable of continuous automatic operation when combined with the thermostat and functionalities of the control unit, such as the error warning system with manual reset.

### 3-4 Heater Dimensions

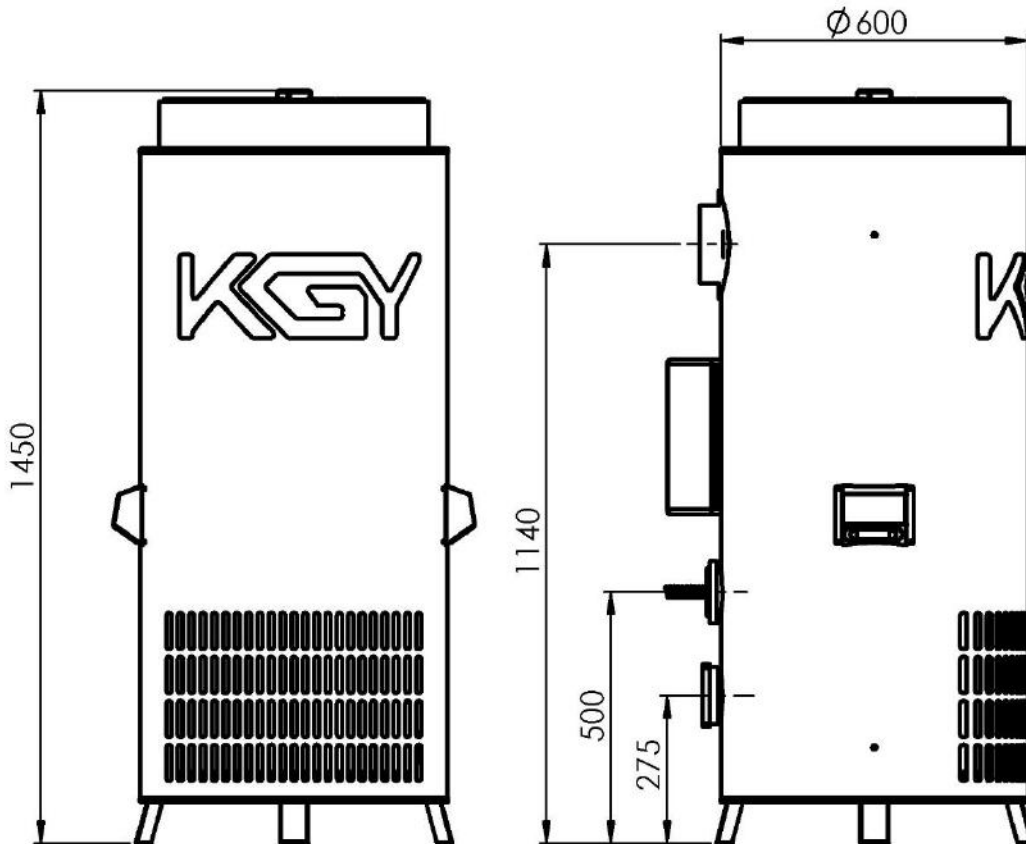
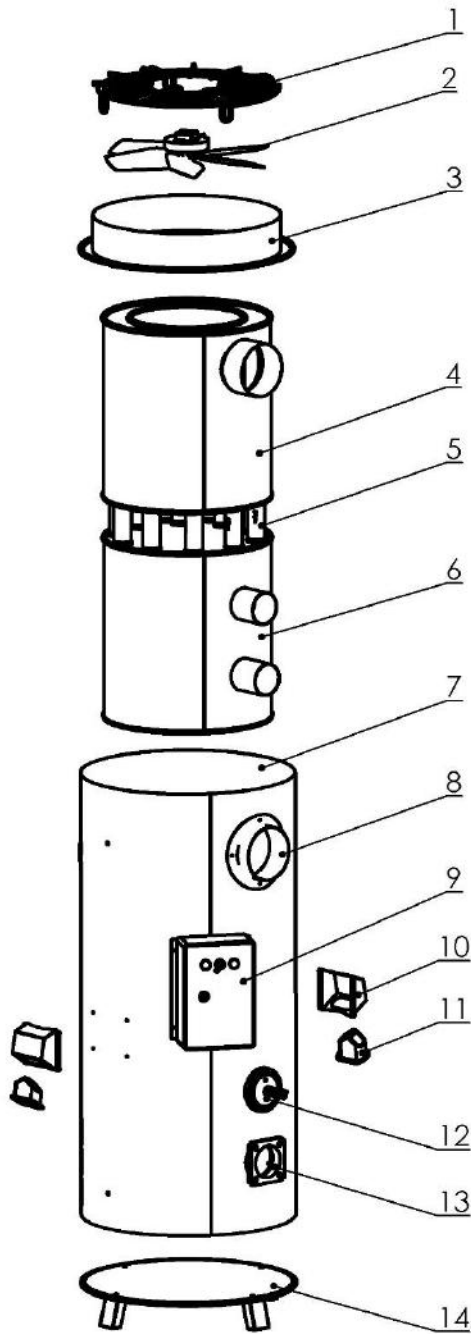

Figure 1, Overview of the Heater







3-5 Internal View of the Heater



1	Fan Guard
2	Blower Fan
3	Housing
4	Heat Exchangers
5	Heat pass pipes
6	Combustion chamber
7	External body and combustion chamber protective
8	Exhaust installation spot
9	Electrical Panel
10	Handle Frame
11	Handle
12	Safety Valve
13	Burner Installation flange
14	Cover and Holder Base

### 3-6 System

The use of a control system assembled with safety equipment, ensures the secure operation of the Heater. Safety features are integrated into the Heater to prevent dangerous accidents and damage. The comprehensive list of safety, control, electrical and mechanical equipment used in this Heater is provided in the table below.

<p><b>Furnace Analogue Thermostat</b></p>	<p>The task of the analogue thermostat is to control the operation of the burner based on the furnace temperature. The thermostat prevents the Heater from operating uncontrollably, ensuring optimal performance and reducing fuel consumption.</p>	
<p><b>Automatic Selection Key</b></p>	<p>The key is used to set the Heater in automatic mode, enabling the automatic activation of the burner and fan.</p>	
<p><b>LED Signal Lights</b></p>	<p>Indicator lamps display the presence of three-phase electricity in the electrical panel.</p>	
<p><b>Electrical Panel</b></p>	<p>The electrical panel is crafted from best ABS materials, providing insulation against water and dust and safeguarding the electrical equipment from external factors.</p>	
<p><b>Propeller</b></p>	<p>The propeller featuring KGY's exclusive design, is made from high-quality polymer materials with high-temperature tolerance. It boasts specialized dynamic balance to move air with minimal noise and maximum pressure.</p>	
<p><b>Body</b></p>	<p>The body is exceptionally robust, fully galvanized, and produced through CNC laser cutting, punching, and bending for the highest precision. This construction minimizes vibration and noise.</p>	

## 4 Installation

### 4-1 Installation obligations

**Note:** The number of Heaters required depends on the size and shape of the desired space, the desired temperature and the weather conditions in your area. For advice and guidance, please contact the company's experts.

### 4-2 Installation guide

**Prior to installation, consider the following:**

- Ensure the main gas or gasoil valve is closed.
- Disconnect the power connection to the Heater.
- Provide a route for the flue to exit.
- Supply the required combustion air from outside the hall through a channel with a diameter equal to burner device's air inlet diameter.

**Install the Heater in a way that:**

- Secure the Heater in place on a fixed platform.
- Establish a connection for a reliable earth wire.
- Maintain a minimum distance of 100 cm between the Heater and the wall.
- Place the Heater on the ground or a concrete platform, using the special bases provided for on-site installation
- Ensure the bottom surface of the Heater is entirely flat and level.
- Verify that no flammable materials are in the vicinity of the Heater. The air outlet should not face such materials. If the channel is not connected, observe the permitted distance in the air outlet path to prevent damage from the hot air emitted.
- Keep the entrance and exhaust of the Heater unobstructed.
- You can connect the Heater to the channel, and the length of the channel can be up to 3 meters.
- Connect the fuel inlet of the Heater is connected to the source, ensuring there are no leaks along the way. Utilize a special gasoil filter at the gasoil inlet.
- If gasoil flows by gravity in the pipe, ensure the height of the bottom of the gasoil tank is higher than the burner's height.
- If using an environmental or automation thermostat, connect it to the input terminal of the device as per Table No. 3.
- Connect the input power cable, alarm and burner power cable to the designated terminals of the device according to Table No. 3

### 4-3 Connections

	<p>Any task related to the Heater, including installation, repair and adjustment of the gas input conversion as well as connection to the natural electricity and gas system, should be carried out by the company's experienced servicemen using high-quality and standard connections.                  During installation, strict adherence to the rules of the electricity and gas companies in your area is essential.</p>
--	--

	<p>Before installation, ensure to coordinate with the regional gas company to verify that the distribution conditions of natural gas and the type and pressure of gas align with the settings of the Heater.</p>
--	--

### 4-4 Gasoil connection

- For gasoil-burning devices, it is crucial to note that the level of the gasoil tank must be higher than the level of the device's gasoil pump. Failure to do so may result in incomplete fuel supply, potentially damaging the gasoil pump and the electric motor of the burner.
- In all instances, the connections for the input fuel, whether gas or gasoil, must be standard and carried out by an expert using fully standard equipment.
- If using gasoil, ensure the use of a gasoil filter and plumb the gasoil as follows.

- Refer to the figure bellow for the movement path of gasoil within the device

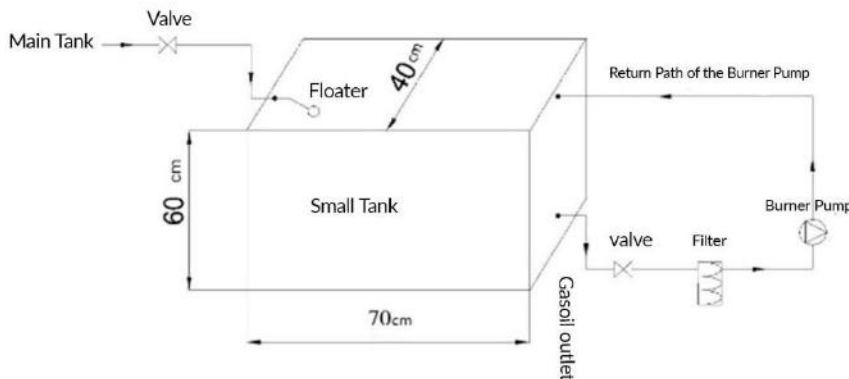

	<p><b>Do not use any pump in the process of transferring gasoil from the source to the Heater. Using a pump in the process can lead to the failure of the heater’s pump and result in improper operation. The buyer is responsible for any consequences</b></p>
--	---

**4-5 Gas Pipeline**

In the gas pipeline from the main line from the National Gas Company to the entrance of the Heater, the integrity of the following items should be considered:

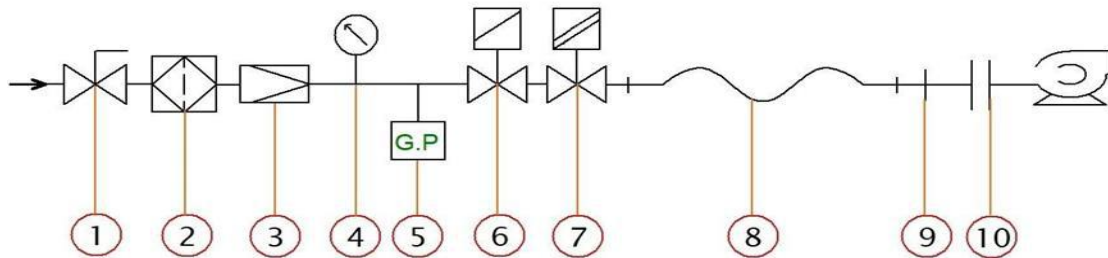
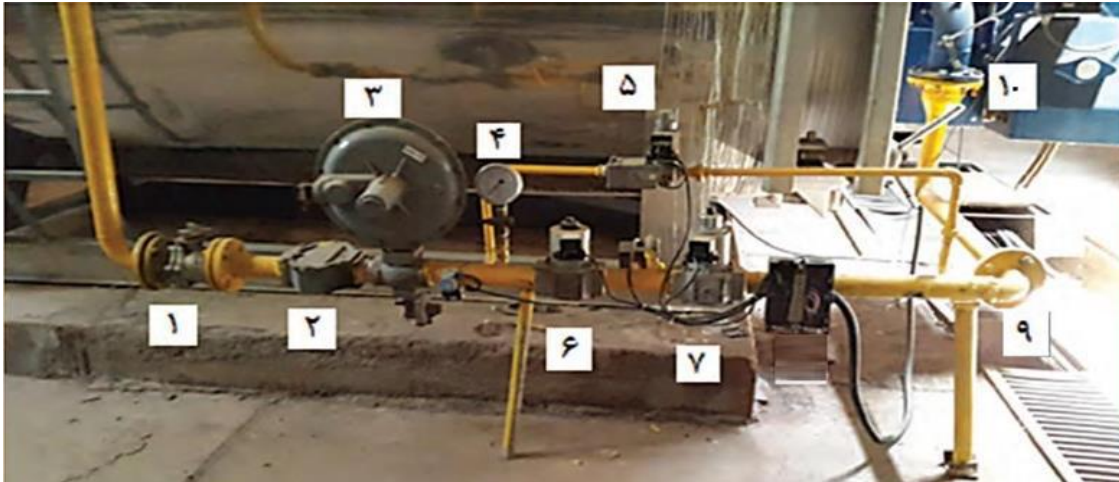

- 1-Gas valve
- 2-Filter
- 3-Regulator
- 4-Barometer
- 5- Gas pressure control switch
- 6- Gas safety valve
- 7- Two-step gas valve
- 8- Gas tube
- 9- Tube diameter exchanger
- 10- Flange connection



The buyer is responsible for the preparation and installation of the mentioned items.

	<p><b>Before installation, be sure to check in coordination with the regional gas company that the distribution conditions of natural gas and the type and pressure of gas match the settings of the Heater.</b></p>
---	--

#### 4-6 Flue Connection

	<p><b>For the installation of the flue, priority is given to the tips and rules provided by National Gas Company.</b></p>
---	---

- 1) Ensure a positive upward slope for horizontal pipes, with the vertical part's height being at least three times the length of the horizontal section. Consider wing items in the installation

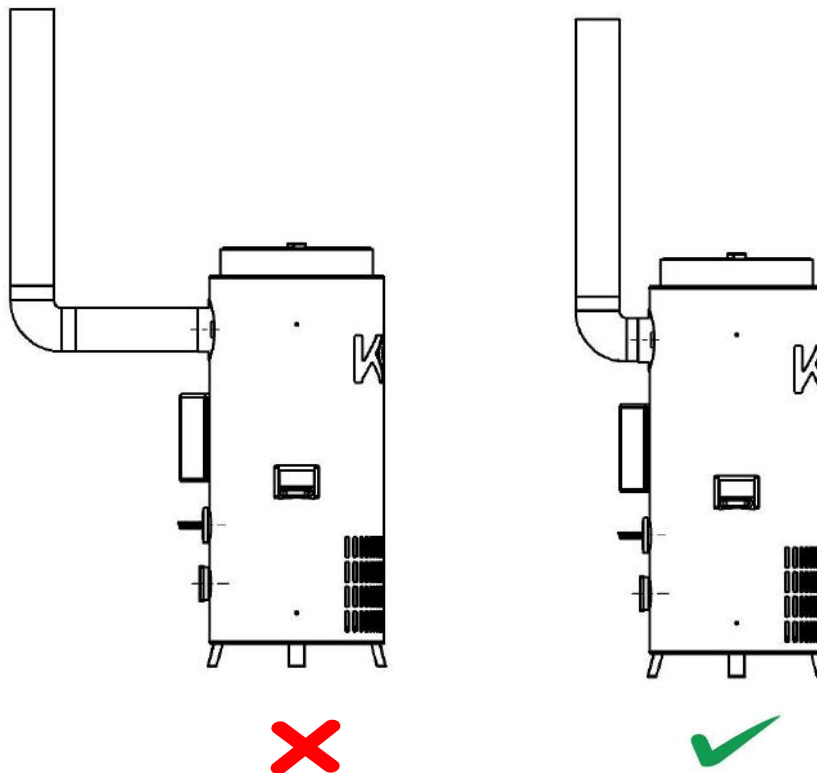

**Figure4: Flue Installation**

- 1) The flue pipe diameter should be equal to or greater than exhaust heater diameter

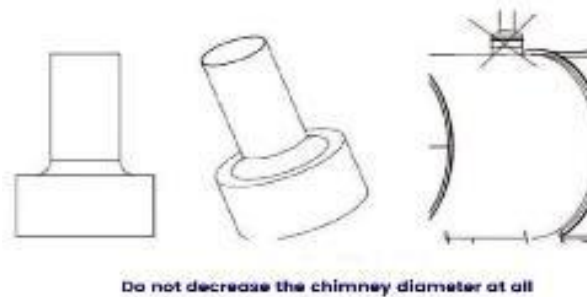

**Figure5**

- 2) Secure the flue using a suitable holder to prevent vibration during operation and to ensure that connections remain intact.
- 3) Minimize unnecessary twisting and turning during installation.
- 4) Install an H-cap at the flue outlet
- 5)

	<p><b>Failure to connect the H-cap is considered inappropriate use and will result the exclusion of the Heater from the warranty.</b></p>
---	---

The H cap must be installed vertically, and it should be avoided to install on horizontally placed pipes, as this condition can lead to the accumulation of smoke and pollutants in the flue pipes, causes the smoke to be pushed back into the flue system.

**An essential point in installing the H cap is to position it at least 60 cm above the roof level.**

#### **4-7 Channel Connection**

Various designs for installing the channel in the heater outlet can be created based on the hall's need.

Below you can find different views illustrating the installation of the channel on the Heater

## 5 Initiation

### 5-1 Electricity

The Heater’s electrical panel is according to the following table

TF	Fan Thermostat
TB	Burner Thermostat
TM	Ambient Thermostat
S1	Manual Fan
S2	Automatic Fan
BU	Burner
IP	Fan motor

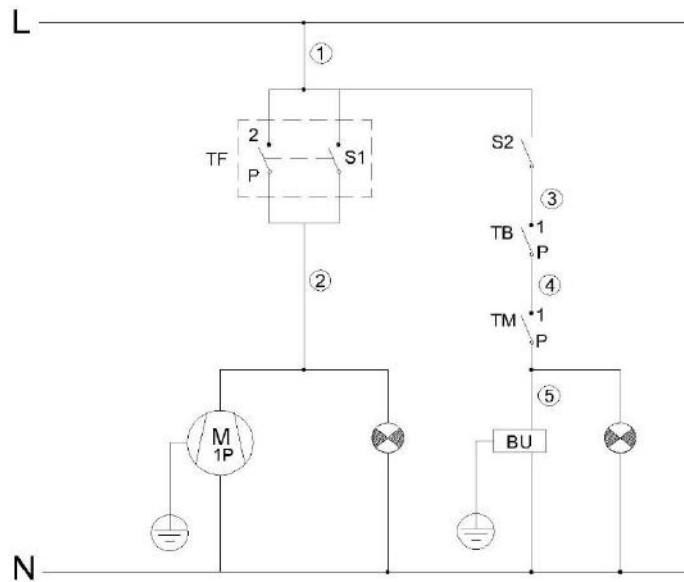

Figure 7 Power Map





**In the event of a power outage during operation, there is a possibility of damaging the furnace. To mitigate potential danger, it is essential to have an emergency power source**

### 5-2 Running

**After correctly completing steps 1-9:**

- 1) Connect the burner input power, placing the burner cable according to the number into the corresponding place inside the panel.
- 2) Connect the burner fueling system to the burner using standard connections.
- 3) If a manual thermostat is used inside the hall, connect its wire to the ambient thermostat inside the panel.
- 4) set the switch on the electrical panel to automatic mode and wait for the burner to turn on.
- 5) To optimize burner performance, prevent direct sunlight from entering the Heater chamber.
- 6) Gasoil enters the burner pump by gravity, so the location of the gasoil tank must be at least one meter above the burner level.
- 7) Ensure the thermostat settings for the fan and the burner are correct (fan at 40 degrees and burner at 110 degrees)
- 8) After turning on the burner, the Heater will work automatically.

	<p><b>It is crucial to note that the emergency turn-off key is reserved critical conditions, and should not be used under normal conditions.</b></p>
--	--

	<p><b>Always allow the Heater fan to continue working until the boiler reaches the set temperature, do not turn off the Heater before stopping the fan.</b></p>
---	---

### 5-3 Adjustment

Adjustments of gas and gasoil pressure, as well as the amount of air mixing, should be performed by the technical expert of the factory. incorrect adjustment may lead to decreased combustion quality, suboptimal fuel consumption, and even a potential of dangers.

	<p><b>Contact the factory or authorized servicemen any needed adjustment, repairs, or part replacement.</b></p>
---	---

### 5-4 Repair and Maintenance

Note: Before conducting any repairs, isolate the electrical and fuel supply system and make the necessary repairs. After completing the required repairs, check the fuel supply system for leaks.

- 1) Regularly check the operation of the burner and electromotor every two months with the help of an expert.
- 2) inspect all sensors, sensitive parts and thermocouples every 2 months, replacing them in case of failure.

If the Heater malfunctions for any reason, check the following:

- 1) Ensure the heater's earth wire is connected.
- 2) confirm proper ventilation of the gas or gas pipe connected to the heater.
- 3) during fan power supply installation, verify that the fan propeller rotates counterclockwise; otherwise, adjust the two phases of the output of the electromotor.
- 4) If the burner does not turn on, check items such as light shining on the glass behind the burner (in gasoil burners), fuel reaching the nozzle causing the burner relay light to turn on (in gasoil burners), and earth connection, gas pressure, and burner electromotor operation (in gas burners).
- 5) if the burner is malfunctioning:
  - Changing the temperature of the fan or burner thermostat can cause system malfunction.
  - The fan thermostat should be fixed at 40 degrees, and the burner thermostat should be set to 110 degrees.
  - Improve the exhaust path in case of backfire; the flue path should be as straight as possible without angles and twists (Figure 4)

If smoke is observed at the exhaust outlet due to insufficient air reaching the burner and the problem persists even after increasing the intake air, use a pipe to supply the burner with intake air from outside the hall.

### 5-5 Service

	<p><b>Do not use water to clean the Heater.</b>  <b>Improper cleaning can damage the Heater.</b></p>
---	--

This device should be checked and adjusted by a specialist at least annually. In proper intervals, the heater's service and dust removal should be conducted thoroughly. Avoid using water in this process. Clean the Heater using an air compressor.

	<p><b>Turn off the main power.</b>  <b>All service and maintenance procedures must be performed by trained and factory-approved personnel.</b></p>
---	--

- Check the operation of the burner and electric motor once every two months.
- Examine the burner nozzle every six months and replace it if it is clogged.
- Periodically clean the gasoil filter to ensure its health and replace it after one year.
- regularly inspect the electrical connections of wires and terminals, as well as thermo-switch, ensuring they are tight.
- tighten the electrical panel annually and ensure that the screws and connections are secure.

## 6 Spare Part

### 7 Ambient Thermostat

To regulate the temperature of an environment, an Ambient Thermostat can be used. It maintains environment's temperature at a desired value by controlling the cooling and heating equipment. Beyond automatic device operation, this function significantly contributes to reducing energy consumption. Ambient Thermostats can be analog, or digital and utilize an automation system.



**Figure 8: Ambient Thermostat**

#### 7-1 Flue Pipe and H Cap

The maximum length of the flue pipe should be 0.45 meters for every 2.5 cm diameter of the flue pipe. Ensure the use of an H cap at the flue outlet. This cap comprises a base and two fins connected by a connector on the base. According to the engineering system principles, the H cap adheres to all necessary standards to be positioned at the highest point of the flue pipes.



**Figure 9: Flue Pipe and H Cap**

## 7-2 Air Transfer Duct

A duct pipe, characterized by a trunk-like body, offers high flexibility. This type of duct is employed to supply incoming air to the burner. It is crucial to use this equipment since the high suction of the fan can disturb the air around the device, affecting proper flame formation. Confirm that the diameter of the air duct matches the diameter of the air inlet of the burner when selecting the duct.



Figure10: Duct Pipe

## 7-3 Burner

**KGY** Company stands as a pioneer in the field of air conditioning, cooling, and heating of buildings. The company has initiated the production of burners under the name **KG** burners. The key feature distinguishing these burners from current examples is the addition of a spiral to the fan. The existence of a spiral not only optimally directs the air to the combustion path but also aids the fan in maintaining balanced pressure, minimizing axial forces on the shaft as much as possible.



Figure11: Yagd Burner



**ECO60**  
USER MANUAL  
AND  
INSTALLATION INSTRUCTIONS

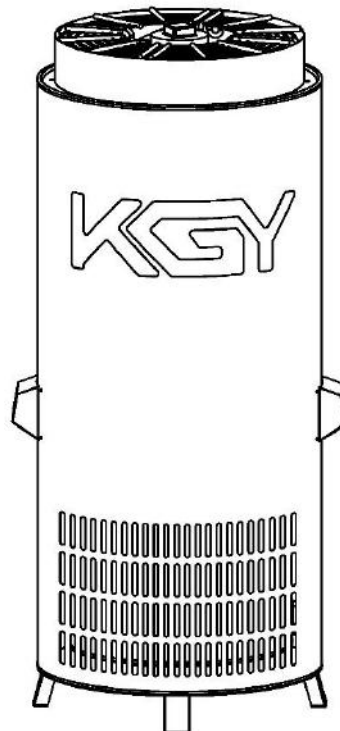

Add: St.Iman,Hosseinabad Rismani,Yazd,Iran  
Tel: +98 35 38369560-1 Fax: +98 35 38369505  
Website:www.KGY.ir Email: info@KGY.ir